



## Designated according to The Construction Products (Amendment etc.) (EU Exit) Regulations 2020

UK Technical Assessment	UKTA-0836-22/6208 of 16/09/2022
Technical Assessment Body issuing the UK Technical Assessment:	British Board of Agrément
Trade name of the construction product:	Drop-in Anchor E / ES
Product family to which the construction product belongs:	Mechanical fasteners for use in concrete
Manufacturer:	MKT-Metall-Kunststoff-Technik GmbH & Co. KG Auf dem Immel 2 67685 Weilerbach Germany
Manufacturing plant(s):	MKT-Metall-Kunststoff-Technik GmbH & Co. KG Auf dem Immel 2 67685 Weilerbach Germany
This UK Technical Assessment contains:	17 pages including 3 annexes which form an integral part of this assessment
This UK Technical Assessment is issued in accordance with The Construction Products (Amendment etc.) (EU Exit) Regulations 2020 on the basis of:	UKAD 330232-00-0601: <i>Mechanical fasteners for use in concrete</i>

**Communication of this UK Technical Assessment, including transmission by electronic means, shall be in full. However, partial reproduction may be made with the written consent of the British Board of Agrément. Any partial reproduction must be identified as such.**

## **1 Technical description of the product**

The Drop-in Anchor E / ES is a fastener manufactured of galvanized steel, stainless steel or high corrosion resistant steel which is placed into a drilled hole and anchored by deformation-controlled expansion

The product description is given in Annex A.

## **2 Specification of the intended use(s) in accordance with the applicable UK Assessment Document (hereinafter UKAD)**

The performances given in Section 3 are only valid if the anchor is used in compliance with the specifications and conditions given in Annex B.

The verifications and assessment methods on which this UK Technical Assessment is based lead to the assumption of a working life of the anchor of at least 50 years. The indications given on the working life cannot be interpreted as a guarantee given by the producer but are to be regarded only as a means for choosing the right products in relation to the expected economically reasonable working life of the works.

## **3 Performance of the product and references to the methods used for its assessment**

### **3.1 Mechanical resistance and stability (BWR 1)**

<b>Essential characteristic</b>	<b>Performance</b>
Characteristic resistance to tension load (static and quasi static loading) Method A	See Annex B2, C1 and C2
Characteristic resistance to shear load (static and quasi static loading)	See Annex C3 and C4
Displacements	See Annex C5
Characteristic resistance and displacements for seismic performance categories C1 and C2	No performance assessed

### **3.2 Safety in case of fire (BWR 2)**

<b>Essential characteristic</b>	<b>Performance</b>
Reaction to fire	Class A1
Resistance to fire	No performance assessed

### **3.3 Hygiene, health and the environment (BWR 3)**

Not relevant

### **3.4 Safety and accessibility in use (BWR 4)**

Not relevant

### **3.5 Protection against noise (BWR 5)**

Not relevant

### **3.6 Energy economy and heat retention (BWR 6)**

Not relevant

### **3.7 Sustainable use of natural resources (BWR 7)**

Performance not assessed

### **3.8 Durability**

<b>Essential characteristic</b>	<b>Performance</b>
Durability	See Annex B1

**4 Assessment and verification of constancy of performance (hereinafter AVCP) system applied**

According to UKAD No. 330232-00-0601 and Annex V of the Construction Products Regulation (Regulation (EU) 305/2011) as brought into UK law and amended, the system of assessment and verification of constancy of performance (AVCP) 1 applies.

**5 Technical details necessary for the implementation of the AVCP system, as provided for in the applicable UKAD**

Technical details necessary for the implementation of the AVCP system are laid down in the control plan deposited with the British Board of Agrément and made available to the UK Approved Bodies involved in the conformity attestation process.

**5.1 UKCA marking for the product/ system must contain the following information:**

- Identification number of the Approved Body
- Name/address of the manufacturer of the product/ system
- Marking with intention of clarification of intended use
- Date of marking
- Number of certificate of constancy of performance
- UKTA number.

On behalf of the British Board of Agrément



Date of Issue: 16 September 2022











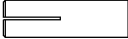

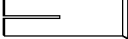

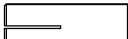
**Hardy Giesler**  
Chief Executive Officer

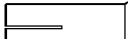

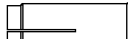
**British Board of Agrément,**  
1<sup>st</sup> Floor Building 3,  
Hatters Lane,  
Croxley Park  
Watford  
WD18 8YG

**ANNEX A1**  
**Product description / Anchor sizes and variations / Installation**

**Drop-in Anchor E / ES**

Anchor sizes and variations					
Drop-in Anchor E (without shoulder)			Drop-in Anchor ES (with shoulder)		
E M6x30			ES M6x30		
E M8x30			ES M8x30		
E M8x40			ES M8x40		
E M10x40			ES M10x30 (zinc plated)		
E M12x50			ES M10x40		
E M12x80			ES M12x50		
E M16x65			ES M12x80		
E M16x80			ES M16x65		
E M20x80			ES M16x80		

**Installation situation**

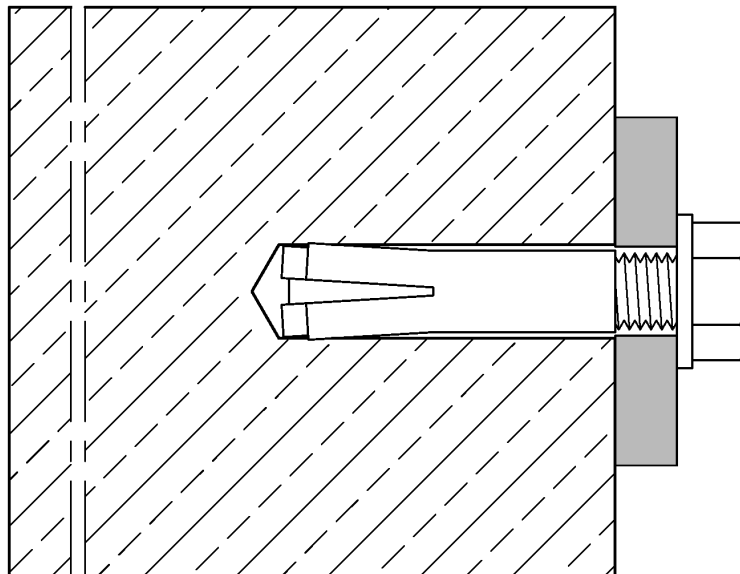

**ANNEX A2**  
**Product description / Materials**

**Table A1: Material**

Part	Designation	Steel, zinc plated	Stainless steel A4	High corrosion resistant steel HCR
1	Anchor sleeve	Cold formed or machining steel, galvanized, EN ISO 4042:2018	Stainless steel (e.g. 1.4401, 1.4404, 1.4571) EN 10088:2014, EN ISO 3506:2020	Stainless steel, 1.4529, 1.4565, EN 10088:2014, EN ISO 3506:2020
2	Cone	Cold formed or machining steel	Stainless steel (e.g. 1.4401, 1.4404, 1.4571) EN 10088:2014	

**Requirements on the fastening screw or the threaded rod and nut according to the engineering documents:**

- Minimum screw-in depth  $L_{smin}$  see Table B1
- The length of screw or the threaded rod shall be determined depending on the thickness of fixture  $t_{fix}$ , available thread length  $L_{th}$  (= maximum screw-in depth) and the minimum screw-in depth  $L_{smin}$ .
- $A_5 > 8$  % Ductility
- Materials
  - **Steel, zinc plated**, property class 4.6 / 4.8 / 5.6 / 5.8 or 8.8 according to EN ISO 898-1:2013 or EN ISO 898-2:2012
  - **Stainless steel A4** or **high corrosion resistant steel HCR**, property class 70 or 80 according to EN ISO 3506:2020

**ANNEX A3**  
**Product description / Dimensions and marking**

**Anchor sleeve**

**Anchor version without shoulder (E)**

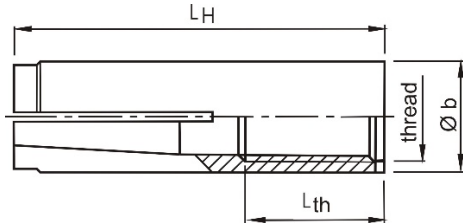

**Anchor version with shoulder (ES)**

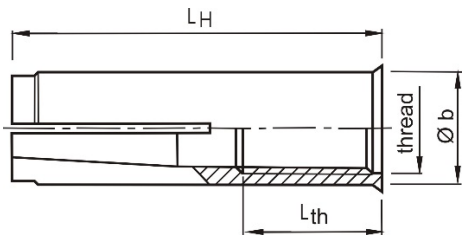

**Marking:** see Table A2

e.g.: E M8x40

identifying mark of manufacturing plant

E anchor identity (version without shoulder)

ES anchor identity (version with shoulder)

M8 size of thread

40 anchorage depth

additional marking

A4 stainless steel

HCR high corrosion resistant steel

**Cone**

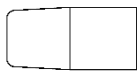

M6x30 and M10x30

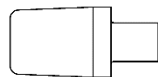

remaining sizes

**Table A2: Dimensions and marking**

Anchor size	Anchor sleeve				Marking			Cone
	thread	Ø b	L <sub>H</sub>	L <sub>th</sub>	Version E (without sleeve)	Version ES (with sleeve)	alternative	
M6x30	M6	8	30	13	E M6x30	ES M6x30	E M6	
M8x30	M8	10	30	13	E M8x30	ES M8x30	E M8	
M8x40	M8	10	40	20	E M8x40	ES M8x40	E M8x40	
M10x30	M10	12	30	12	-	ES M10x30	E M10x30	
M10x40	M10	12	40	15	E M10x40	ES M10x40	E M10	
M12x50	M12	15	50	18	E M12x50	ES M12x50	E M12	
M12x80	M12	15	80	45	E M12x80	ES M12x80	E M12x80	
M16x65	M16	19.7	65	23	E M16x65	ES M16x65	E M16	
M16x80	M16	19.7	80	38	E M16x80	ES M16x80	E M16x80	
M20x80	M20	24.7	80	34	E M20x80	-	E M20	

Dimensions in mm

ANNEX A4  
Product description / Setting tools / Dimensions and marking

Setting tool for marking

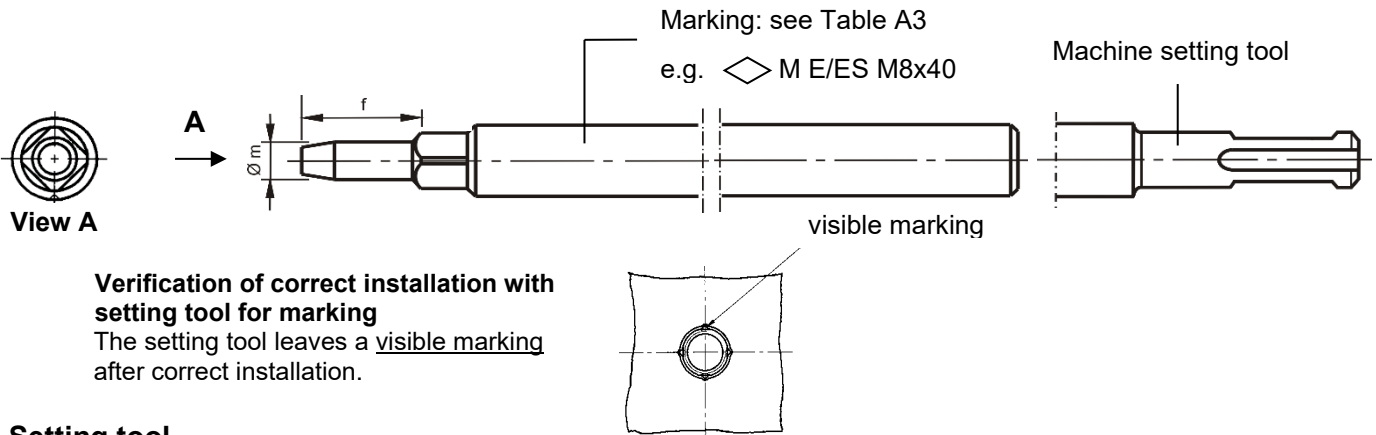

Setting tool

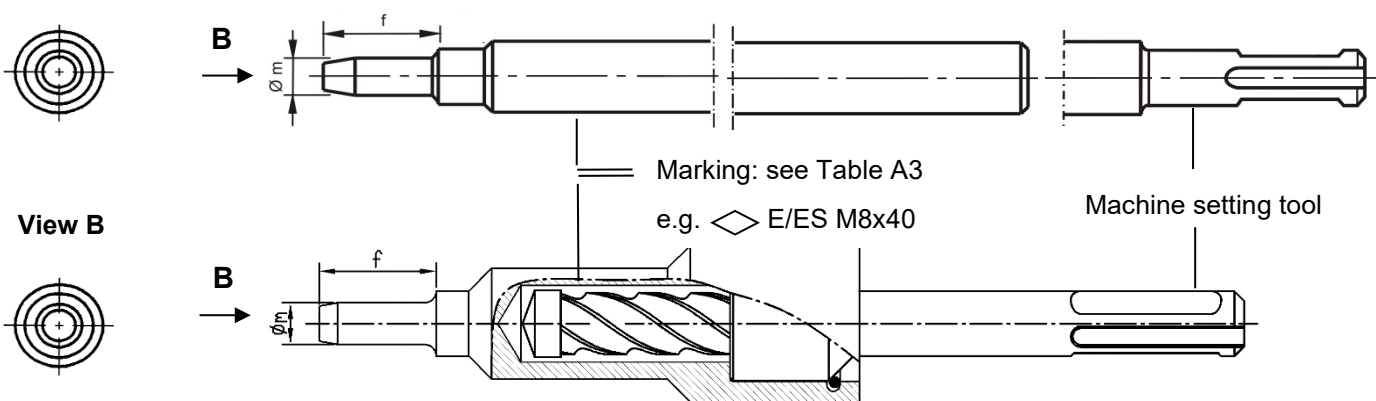

Table A2: Dimensions and marking of setting tools

Anchor size	$\varnothing m$	f	Setting tool for marking		Setting tool	
			Marking	alternative	Marking	alternative
M6x30	4,9	17	$\diamond M E/ES M6x30$	$\diamond M E M6$	$\diamond E/ES M6x30$	$\diamond E M6$
M8x30	6,4	18	$\diamond M E/ES M8x30$	$\diamond M E M8$	$\diamond E/ES M8x30$	$\diamond E M8$
M8x40	6,4	28	$\diamond M E/ES M8x40$	$\diamond M E M8x40$	$\diamond E/ES M8x40$	$\diamond E M8x40$
M10x30	8,0	18	$\diamond M ES M10x30$	$\diamond M E M10x30$	$\diamond ES M10x30$	$\diamond E M10x30$
M10x40	8,0	24	$\diamond M E/ES M10x40$	$\diamond M E M10$	$\diamond E/ES M10x40$	$\diamond E M10$
M12x50	10,0	30	$\diamond M E/ES M12x50$	$\diamond M E M12$	$\diamond E/ES M12x50$	$\diamond E M12$
M12x80	10,0	60	$\diamond M E/ES M12x80$	$\diamond M E M12x80$	$\diamond E/ES M12x80$	$\diamond E M12x80$
M16x65	13,5	36	$\diamond M E/ES M16x65$	$\diamond M E M16$	$\diamond E/ES M16x65$	$\diamond E M16$
M16x80	13,5	51	$\diamond M E/ES M16x80$	$\diamond M E M16x80$	$\diamond E/ES M16x80$	$\diamond E M16x80$
M20x80	16,5	50	$\diamond M E M20x80$	$\diamond M E M20$	$\diamond E M20x80$	$\diamond E M20$

Dimensions in mm



## **ANNEX B1**

### **Intended Use / Specifications of intended use**

#### **Anchorage subject to:**

- Static and quasi-static loads

#### **Base materials:**

- Compacted, reinforced or unreinforced normal weight concrete, without fibres according to EN 206:2013 + A1:2016
- Uncracked concrete
- Strength classes C20/25 to C50/60 according to EN 206:2013 + A1:2016

#### **Use conditions (Environmental conditions):**

- Structures subject to dry internal conditions (all materials)
- For all other conditions applies:  
Use according to EN 1993-1-4:2015 corresponding to corrosion resistance class CRC according to Annex A2, Table A1:
  - Stainless steel A4: CRC III
  - High corrosion resistant steel HCR: CRC V
- Anchor types M6x30 A4 and M8x30 A4 only for dry internal exposure

#### **Design:**

- Anchorages are designed under the responsibility of an engineer experienced in anchorages and concrete work.
- Verifiable calculation notes and drawings are prepared taking account of the loads to be anchored. The position of the anchor is indicated on the design drawings (e.g. position of the anchor relative to reinforcement or to supports, etc.).
- The strength class and the length of the fastening screw or threaded rod shall be defined by the designing engineer
- Design of fastenings according EN 1992-4:2018 (and TR 055, if necessary)
- Anchor sizes M6x30, M8x30 and M10x30 for statically indeterminate structural components only, when in case of failure, the load can be distributed to other fasteners.

#### **Installation:**

- Anchor installation in accordance with the manufacturer's specifications and drawings and using the appropriate tools
- Drill hole by hammer drilling or vacuum drilling

**ANNEX B2**  
**Intended Use / Installation parameters**

Table B1: Installation parameters

Anchor size		M6x30	M8x30	M8x40	M10x30	M10x40	M12x50	M12x80	M16x65	M16x80	M20x80
Depth of drill hole	$h_0 =$ [mm]	30	30	40	30	40	50	80	65	80	80
Drill hole diameter	$d_0 =$ [mm]	8	10	10	12	12	15	15	20	20	25
Cutting diameter of drill bit	$d_{cut} \leq$ [mm]	8.45	10.45	10.45	12.5	12.5	15.5	15.5	20.55	20.55	25.55
Max. installation torque <sup>1)</sup>	$T_{inst} \leq$ [Nm]	4	8	8	15	15	35	35	60	60	120
Diameter of clearance hole in the fixture	$d_f \leq$ [mm]	7	9	9	12	12	14	14	18	18	22
Thread length	$L_{th}$ [mm]	13	13	20	12	15	18	45	23	38	34
Minimum screw-in depth	$L_{sdmin}$ [mm]	7	9	9	10	11	13	13	18	18	22
<b>Steel, zinc plated</b>											
Minimum thickness of member	$h_{min}$ [mm]	100	100	100	120	120	130	130	160	160	200
Minimum spacing	$s_{min}$ [mm]	55	60	80	100	100	120	120	150	150	160
Minimum edge distance	$c_{min}$ [mm]	95	95	95	115	135	165	165	200	200	260
<b>Stainless steel A4, HCR</b>											
Minimum thickness of member	$h_{min}$ [mm]	100	100	100	-	130	140	140	160	160	250
Minimum spacing	$s_{min}$ [mm]	50	60	80	-	100	120	120	150	150	160
Minimum edge distance	$c_{min}$ [mm]	80	95	95	-	135	165	165	200	200	260

<sup>1)</sup> If the screw or threaded rod is otherwise secured against unscrewing, the torque can be omitted

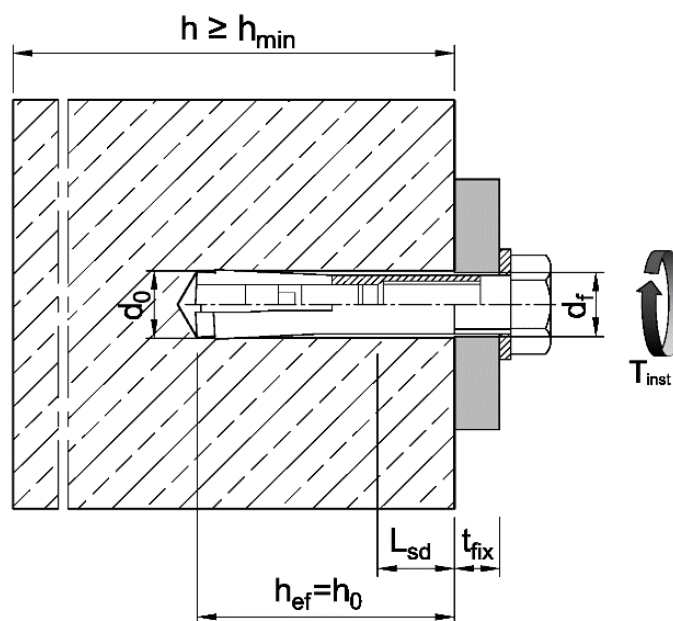

**ANNEX B3**  
Intended Use / Installation instructions

**Installation instructions**

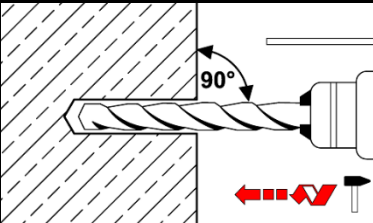
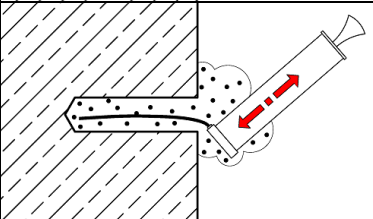
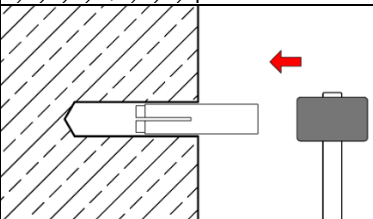
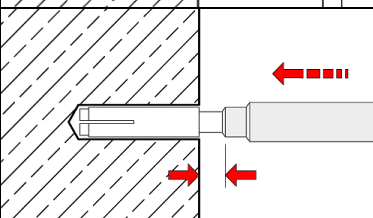
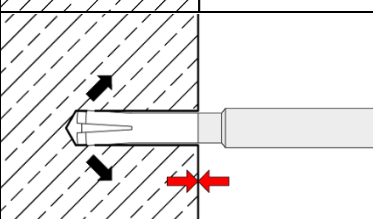
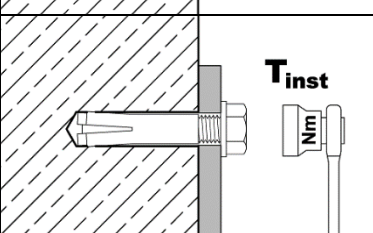
1		<p>Drill hole perpendicular to concrete surface. Using vacuum drill bit proceed with step 3.</p>
2		<p>Blow out dust. Alternatively, vacuum clean down to the bottom of the hole.</p>
3		<p>Drive in anchor.</p>
4		<p>Drive in cone by using setting tool.</p>
5		<p>Shoulder of setting tool must fit on anchor rim.</p>
6		<p>Turn in screw or threaded rod with nut, observe minimum screw-in depth (see Annex B2). Apply installation torque <math>T_{inst}</math>.</p>

## ANNEX C1

### Performance / Characteristics values for tensions loads, zinc plated steel

**Table C1:** Characteristic values for **tension loads, zinc plated steel**

Anchor size			M6x30	M8x30	M8x40	M10x30	M10x40	M12x50	M12x80	M16x65 M16x80	M20x80			
Installation factor	$\gamma_{inst}$	[-]	1.2											
<b>Steel failure</b>														
Characteristic resistance	property class	$N_{Rk,s}$	[kN]	4.6	8.0	14.6	23.2		33.7		62.8	98.0		
				4.8	8.0	14.6	18.0	20.2	33.7		62.8	98.0		
				5.6	10.0	18.3		18.0	20.2	42.1		78.3	122.4	
				5.8	10.0	17.6	18.3	18.0	20.2	40.2	42.1	67.1	106.4	
				8.8	15.0	17.6	19.9	18.0	20.2	40.2	43.0	67.1	106.4	
Partial factor	property class	$\gamma_{Ms}^{1)}$	[-]	2.0										
				2.0			1.5		2.0					
				1.5									1.6	
<b>Pull-out failure</b>														
Characteristic resistance in concrete C20/25	$N_{Rk,p}$	[kN]	8.1	8.1	9.0	8.1	12.4	17.4	17.4	25.8	35.2			
Increasing factor	$\psi_C$	[-]	$\left(\frac{f_{ck}}{20}\right)^{0,5}$		$\left(\frac{f_{ck}}{20}\right)^{0,3}$	$\left(\frac{f_{ck}}{20}\right)^{0,5}$								
<b>Splitting</b>														
Characteristic resistance in concrete C20/25	$N^0_{Rk,sp}$	[kN]	min ( $N_{Rk,p}$ ; $N^0_{Rk,c}$ )											
Characteristic edge distance	$c_{cr,sp}$	[mm]	95	95	95	115	135	165		200	260			
Characteristic spacing	$s_{cr,sp}$	[mm]	$2 \cdot c_{cr,sp}$											
<b>Concrete cone failure</b>														
Effective anchorage depth	$h_{ef}$	[mm]	30	30	40	30	40	50	80	$\frac{65}{80}^{2)}$	80			
Characteristic edge distance	$c_{cr,N}$	[mm]	$1.5 h_{ef}$											
Characteristic spacing	$s_{cr,N}$	[mm]	$2 \cdot c_{cr,N}$											
Factor	uncracked concrete	$k_{ucr,N}$	11.0											
	cracked concrete	$k_{cr,N}$	No performance assessed											

<sup>1)</sup> in absence of other national regulations

<sup>2)</sup> for M16x80

## ANNEX C2

### Performance / Characteristics values for tensions loads, stainless steel A4, HCR

**Table C2:** Characteristic values for **tension loads, stainless steel A4, HCR**

Anchor size			M6x30	M8x30	M8x40	M10x40	M12x50 M12x80	M16x65 M16x80	M20x80
Installation factor	$\gamma_{inst}$	[-]	1.0						
<b>Steel failure</b>									
Characteristic resistance (property class 70)	$N_{Rk,s}$	[kN]	14.1	23.3		29.4	50.2	83.8	133.0
Characteristic resistance (property class 80)	$N_{Rk,s}$	[kN]	17.5	23.3		29.4	50.2	83.8	133.0
Partial factor	$\gamma_{Ms}^{1)}$	[-]	1.87						
<b>Pull-out failure</b>									
Characteristic resistance in concrete C20/25	$N_{Rk,p}$	[kN]	8.1	8.1	11.0	12.4	17.4	25.8	35.2
Increasing factor	$\psi_C$	[-]	$\left(\frac{f_{ck}}{20}\right)^{0,5}$		$\left(\frac{f_{ck}}{20}\right)^{0,3}$	$\left(\frac{f_{ck}}{20}\right)^{0,5}$			
<b>Splitting failure</b>									
Characteristic resistance in concrete C20/25	$N^0_{Rk,sp}$	[kN]	$\min(N_{Rk,p}; N^0_{Rk,c})$						
Edge distance	$C_{cr,sp}$	[mm]	80	95	95	135	165	200	260
Spacing	$S_{cr,sp}$	[mm]	$2 \cdot C_{cr,sp}$						
<b>Concrete cone failure</b>									
Effective anchorage depth	$h_{ef}$	[mm]	30	30	40	40	50 80 <sup>2)</sup>	65 80 <sup>2)</sup>	80
Edge distance	$C_{cr,N}$	[mm]	$1.5 h_{ef}$						
Spacing	$S_{cr,N}$	[mm]	$2 \cdot C_{cr,N}$						
Factor	uncracked concrete	$k_{ucr,N}$	11.0						
	cracked concrete	$k_{cr,N}$	No performance assessed						

<sup>1)</sup> in absence of other national regulations

<sup>2)</sup> for M12x80 and M16x80

## ANNEX C3

### Performance / Characteristics values for shear loads, zinc plated steel

**Table C3:** Characteristic values for shear loads, zinc plated steel

Anchor size				M6x30	M8x30	M8x40	M10x30	M10x40	M12x50	M12x80	M16x65 M16x80	M20x80	
<b>Steel failure without lever arm</b>													
Characteristic resistance	property class	4.6	$V_{Rk,s}$ [kN]	4.0	7.3	11.6	9.6	16.8		31.3	49.0		
		4.8		4.0	7.3	10.1	10.1	16.9		31.3	49.0		
		5.6		5.0	9.1	10.1	9.6	21.1		39.2	61.2		
		5.8		5.0	6.9	10.1	7.2	19.4	21.1	33.5	53.2		
		8.8		5.0	6.9	10.1	7.2	19.4	21.5	33.5	53.2		
Partial factor	property class	4.6	$\gamma_{Ms}^{1)}$ [-]	1.67									
		5.6		1.67			1.25	1.67					
		4.8		1.25									1.33
		5.8											
		8.8											
Ductility factor			$k_7$	[-]									1.0
<b>Steel failure with lever arm</b>													
Characteristic bending resistance	property class	4.6	$M_{Rk,s}$ [Nm]	6.1	15	30		52		133	259		
		4.8		7.6	19	37		65		166	324		
		5.6		12	30	59	60	105	266	519			
		5.8											
Partial factor	property class	4.6	$\gamma_{Ms}^{1)}$ [-]	1.67									
		5.6		1.25									
		4.8											
		5.8											
		8.8											
Ductility factor			$k_7$	[-]									1.0
<b>Concrete pry-out failure</b>													
Pry-out factor			$k_8$	[-]					1.0	1.5	2.0		
<b>Concrete edge failure</b>													
Effective length of fastener in shear loading			$l_f$	[mm]	30	30	40	30	40	50	80	$\frac{65}{80}^{2)}$	80
Outside diameter of fastener			$d_{nom}$	[mm]	8	10		12		15		20	25

<sup>1)</sup> in absence of other national regulations

<sup>2)</sup> for M16x80

## ANNEX C4

### Performance / Characteristics values for shear loads, stainless steel A4, HCR

Table C4: Characteristic values for **shear loads, stainless steel A4, HCR**

Anchor size		M6x30	M8x30	M8x40	M10x40	M12x50	M12x80	M16x65	M16x80	M20x80
<b>Steel failure without lever arm</b>										
Characteristic resistance (property class 70)	$V_{Rk,s}^0$ [kN]	7.0	10.6	13.4	25.1	41.9	66.5			
Characteristic resistance (property class 80)	$V_{Rk,s}^0$ [kN]	8.7	10.6	13.4	25.1	41.9	66.5			
Partial factor	$\gamma_{Ms}^{(1)}$ [-]	1.56								
Ductility factor	$k_7$ [-]	1.0								
<b>Steel failure with lever arm</b>										
Characteristic bending resistance (property class 70)	$M_{Rk,s}^0$ [Nm]	11	26	52	92	233	454			
Partial factor	$\gamma_{Ms}^{(1)}$ [-]	1.56								
Characteristic bending resistance (property class 80)	$M_{Rk,s}^0$ [Nm]	12	30	60	105	266	519			
Partial factor	$\gamma_{Ms}^{(1)}$ [-]	1.33								
Ductility factor	$k_7$ [-]	1.0								
<b>Concrete pry-out failure</b>										
Pry-out factor	$k_8$ [-]	1.0	1.7				2.0			
<b>Concrete edge failure</b>										
Effective length of fastener in shear loading	$l_f$ [mm]	30	30	40	40	50	80	65	80	80
Outside diameter of fastener	$d_{nom}$ [mm]	8	10		12	15		20		25

<sup>1)</sup> in absence of other national regulations

**ANNEX C5**  
**Performance / Displacements**

Table C5: Displacements under tension loads

Anchor size			M6x30	M8x30	M8x40	M10x30	M10x40	M12x50 M12x80	M16x65 M16x80	M20x80
<b>Steel, zinc plated</b>										
Tension load in uncracked concrete	N	[kN]	3	3	3.6	3.3	4.8	6.4	10	14.8
Displacements	$\delta_{N0}$	[mm]	0.24							
	$\delta_{N\infty}$	[mm]	0.36							
<b>Stainless steel A4 / HCR</b>										
Tension load in uncracked concrete	N	[kN]	4	4	4.3	- <sup>1)</sup>	6.1	8.5	12.6	17.2
Displacements	$\delta_{N0}$	[mm]	0.12							
	$\delta_{N\infty}$	[mm]	0.24							

<sup>1)</sup> Anchor version is not part of the UKTA

Table C6: Displacements under shear loads

Anchor size			M6x30	M8x30	M8x40	M10x30	M10x40	M12x50 M12x80	M16x65 M16x80	M20x80
<b>Steel, zinc plated</b>										
Shear load in uncracked concrete	V	[kN]	2	4	4	5.7	4.0	11.3	18.8	32.2
Displacements	$\delta_{V0}$	[mm]	0.9	0.9	1.0	1.5	0.6	1.2	1.2	1.6
	$\delta_{V\infty}$	[mm]	1.3	1.3	1.5	2.3	0.9	1.9	1.9	2.4
<b>Stainless steel A4 / HCR</b>										
Shear load in uncracked concrete	V	[kN]	3.5	5.2	5.2	- <sup>1)</sup>	6.5	11.5	19.2	30.4
Displacements	$\delta_{V0}$	[mm]	1.9	1.1	0.7	- <sup>1)</sup>	1.0	1.7	2.4	2.6
	$\delta_{V\infty}$	[mm]	2.8	1.6	1.0	- <sup>1)</sup>	1.5	2.6	3.6	3.8

<sup>1)</sup> Anchor version is not part of the UKTA





**British Board of Agrément,**  
1<sup>st</sup> Floor Building 3  
Hatters Lane  
Croxley Park  
Watford  
WD18 8YG